

# PLAYGROUND SPIELPLATZ

# PLAC ZABAW AIRE DE JEUX

(366 x 293 x h262cm)

003\_08780\_12012024

## FLAPPI V2

INSTALLATION INSTRUCTIONS  
MONTAGEANLEITUNG

INSTRUKCJA MONTAŻU  
GUIDE D'INSTALLATION

Warranty period - 2 years from purchase date

Garantiezeit - 2 Jahre ab Kaufdatum

Okres gwarancji - 2 lata od momentu zakupu towaru

Période de garantie - 2 ans à compter de l'achat

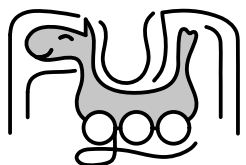

fungoo®

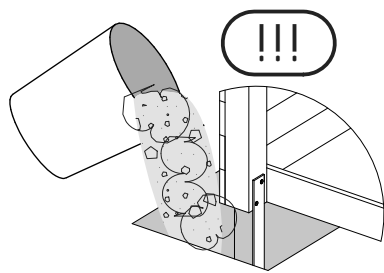

EN - 71

### WARNINGS!

Only for home use.

Dedicated for external use only.

Not suitable for children under 3 years old.

Risk of falling down and/or hitting.

Maximum user weight is up to 50 kg.

Maximum number of users staying on the  
playground at the same time: 6.

### OSTRZEŻENIA!

Tylko do użytku domowego.

Przeznaczony do użytku na zewnątrz.

Nie przeznaczony dla dzieci poniżej 3 roku życia.

Niebezpieczeństwo upadku i/lub uderzenia.

Maksymalna waga użytkownika to 50 kg.

Maksymalna liczba użytkowników przebywających  
na placu zabaw w tym samym czasie: 6.

### ACHTUNG!

Nur für den privaten, häuslichen Bereich.

Ausschließlich für die Verwendung im Freien.

Nicht geeignet für Kinder unter 3 Jahren.

Stolper- und / oder Sturzgefahr

Höchstgewicht pro Einzelkind beträgt 50 kg

Der Aufenthalt auf diesem Spielturm ist max. : 6.  
Kindern gleichzeitig erlaubt.

### AVERTISSEMENT!

Aire exclusivement destinée à un usage privé.

Aire exclusivement destinée à un usage en extérieur.

Prévue pour les enfants de plus de 3 ans.

Danger de chute ou de choc.

Poids maximal d'un utilisateur : 50 kg.

Nombre maximal d'utilisateurs présents en  
même temps sur la même aire de jeux: 6.

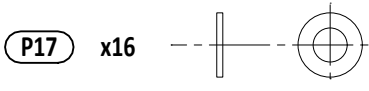
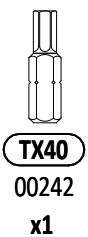
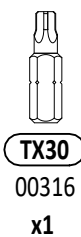
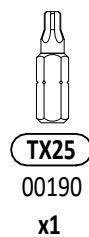
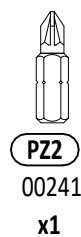
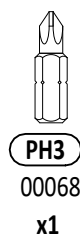
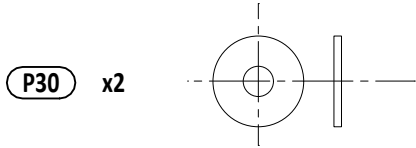
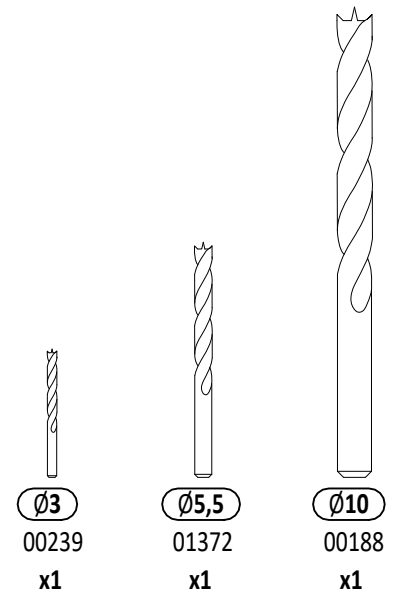
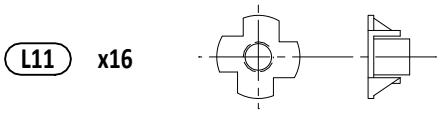
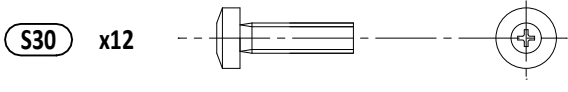
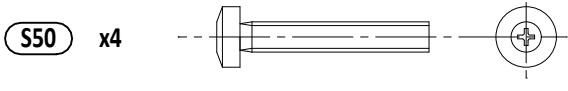
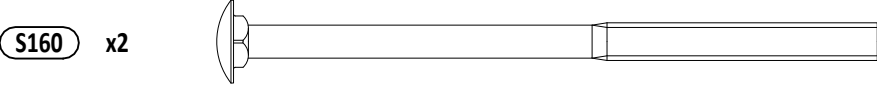
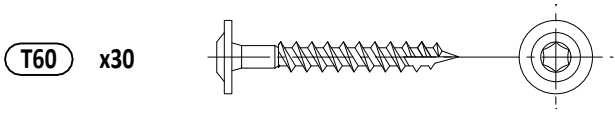
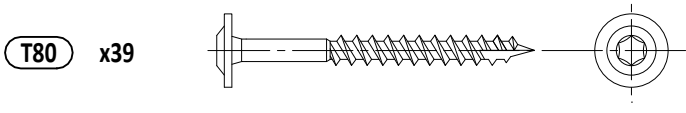
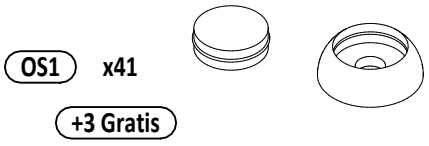
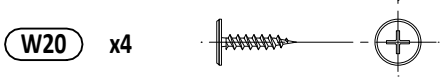
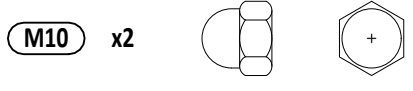
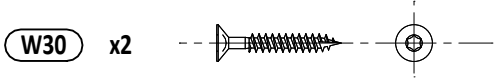
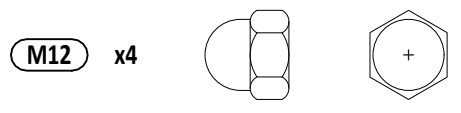
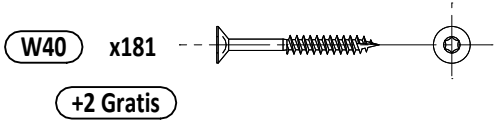
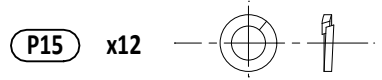
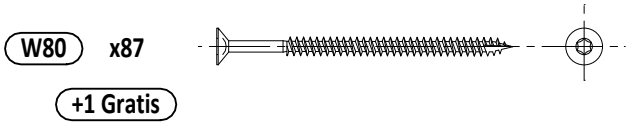

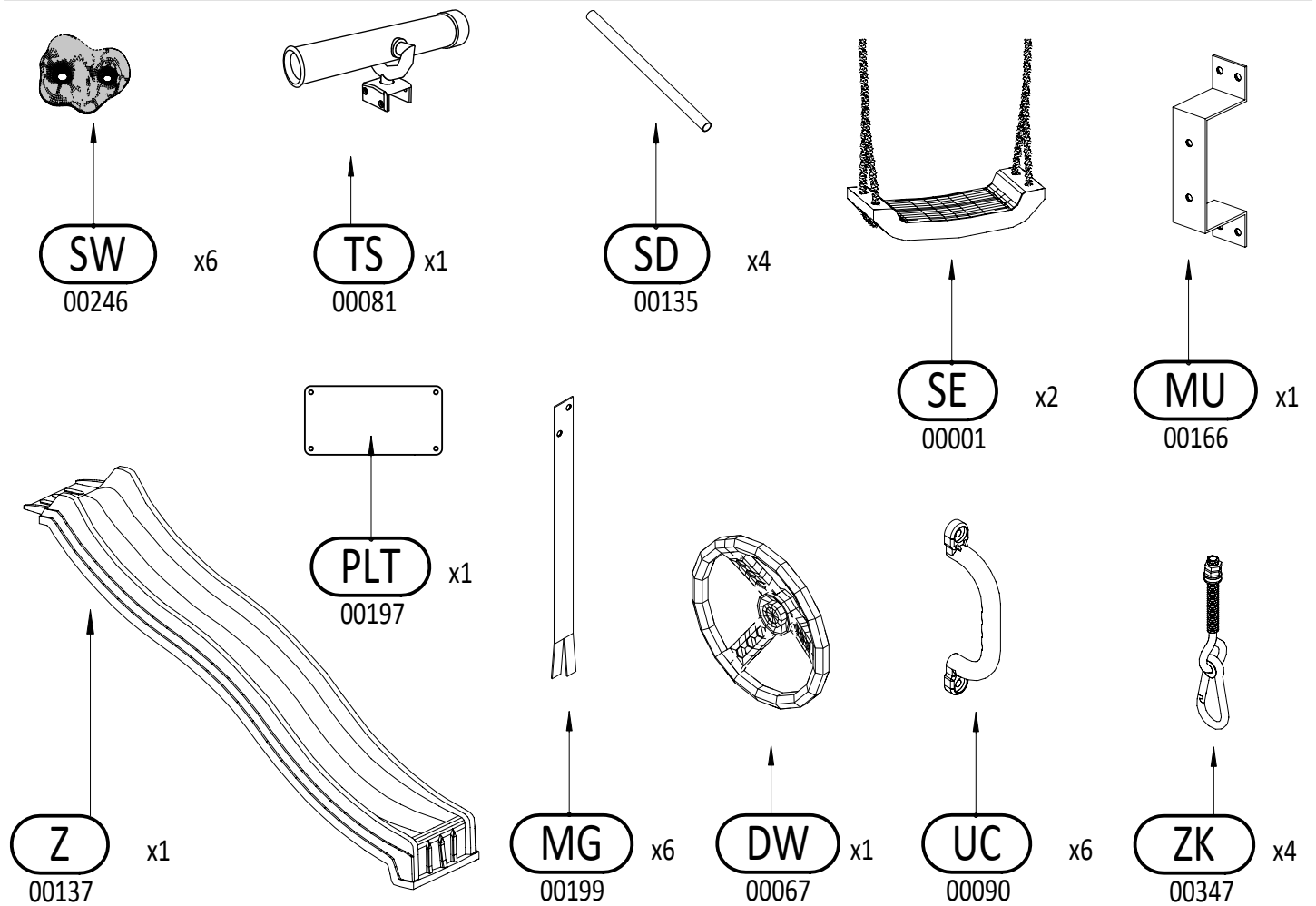
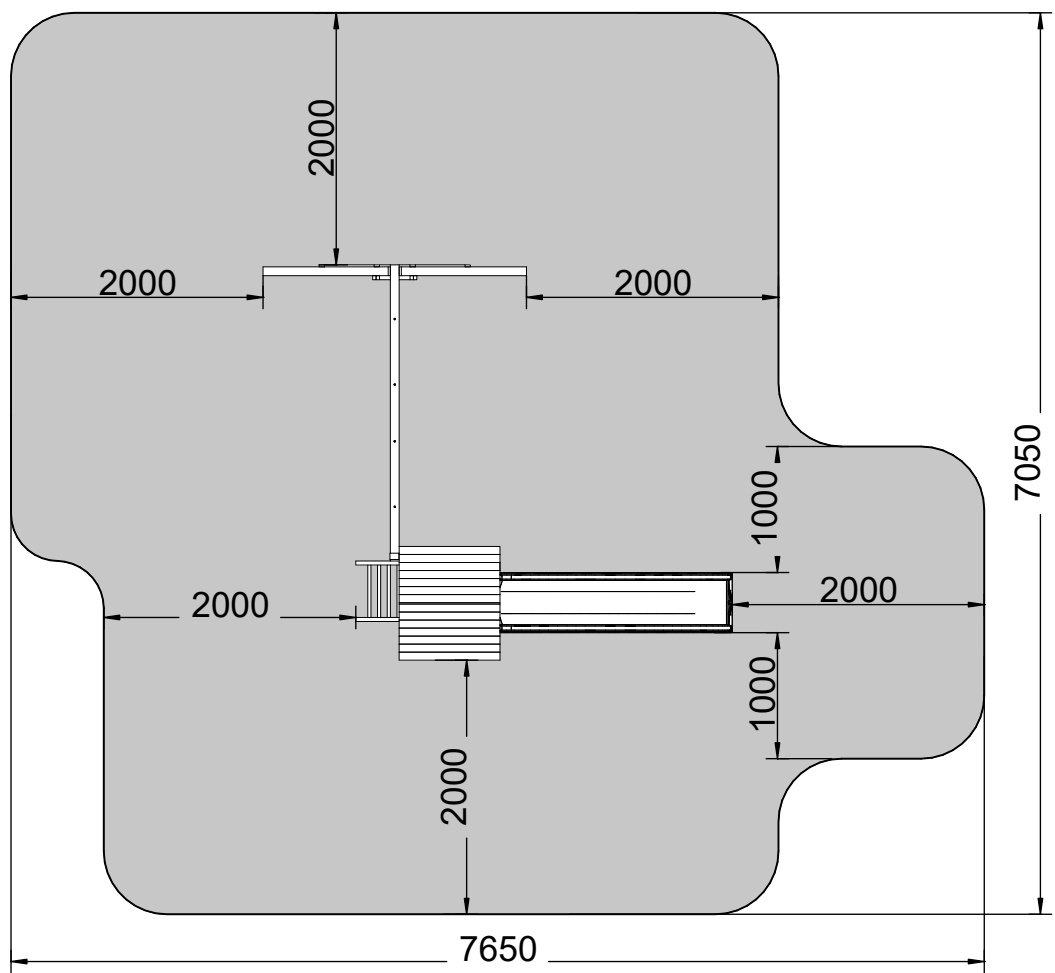

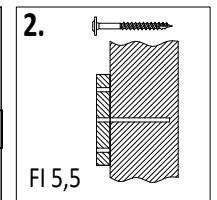
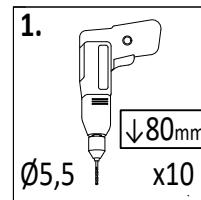
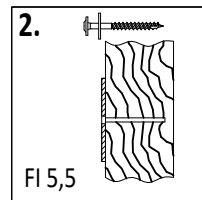
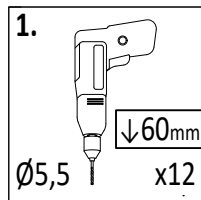
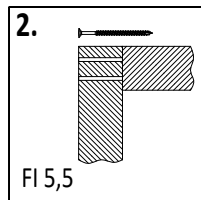
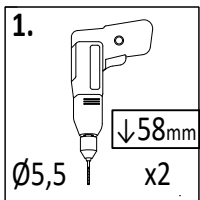
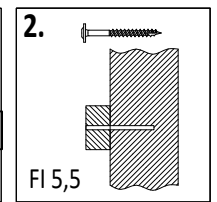
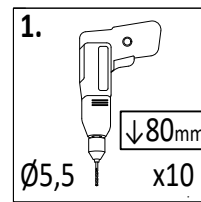
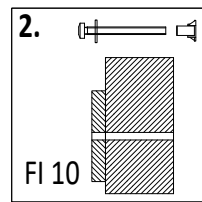
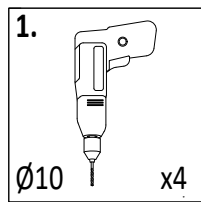
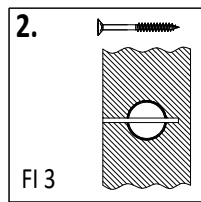
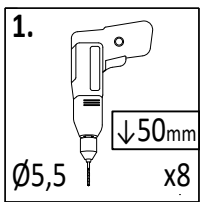
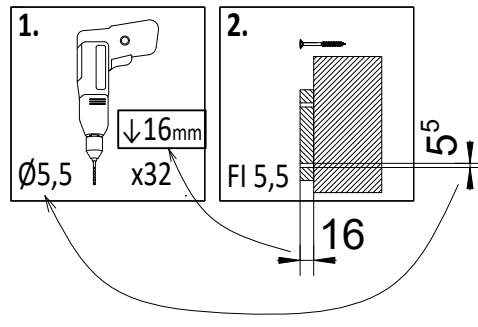
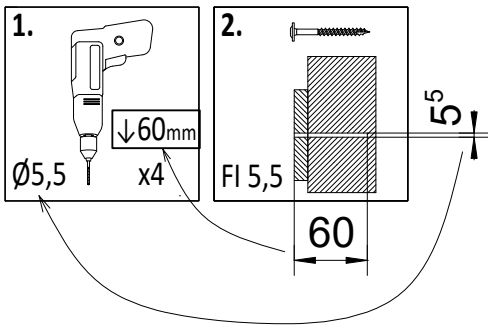
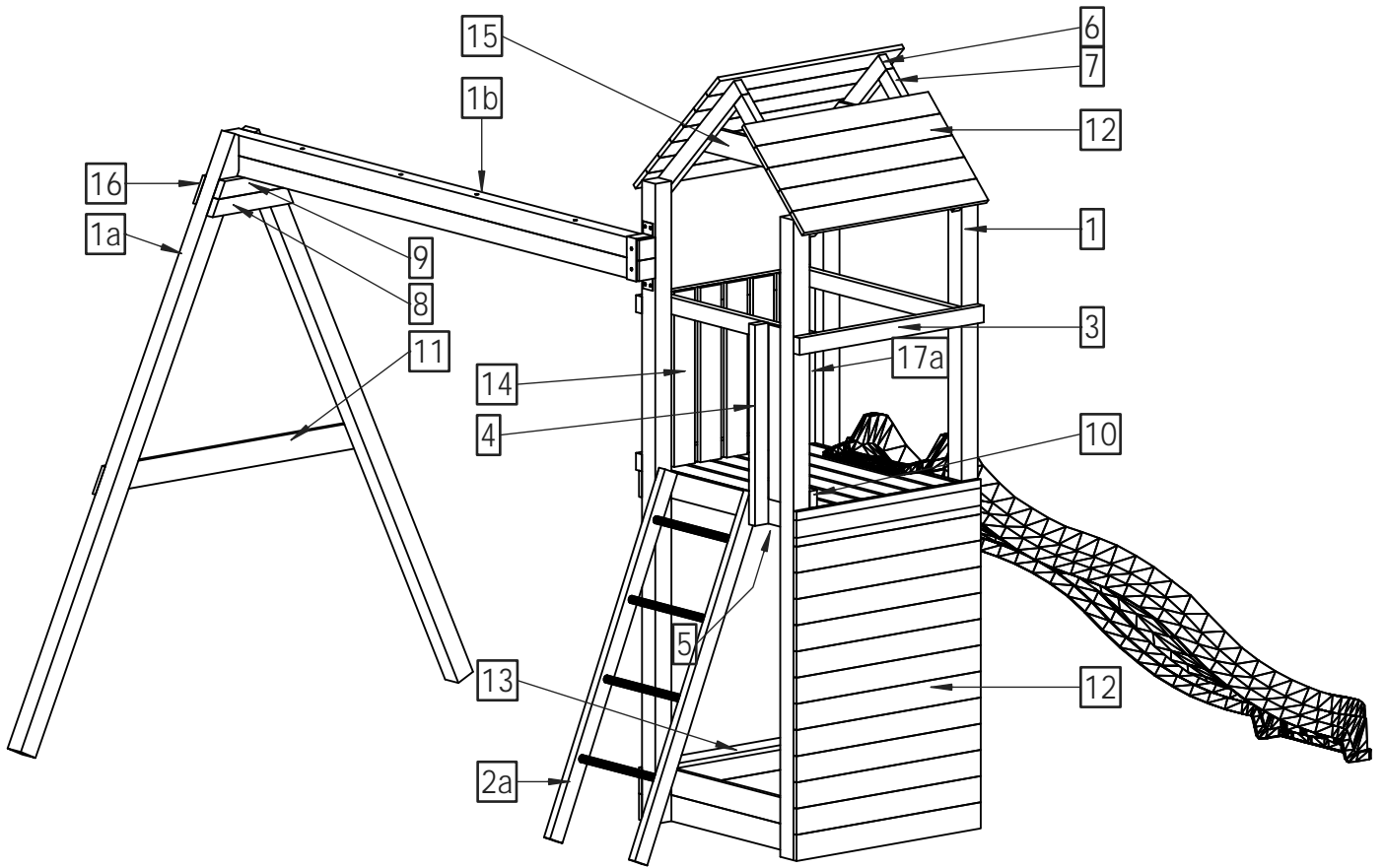

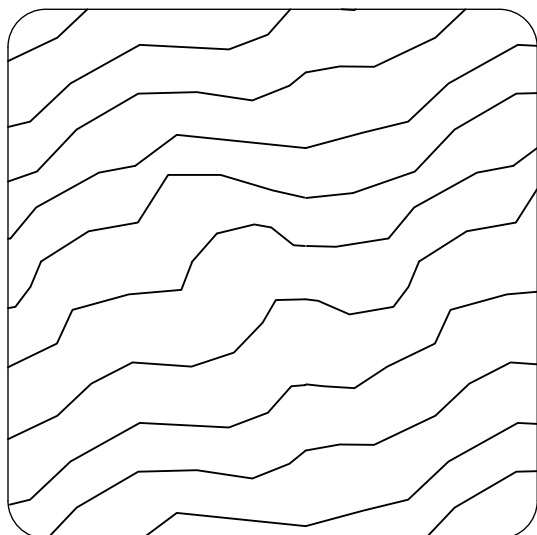

- **7,0 x 7,0 cm**

Lp.	Kod	Wymiary [mm]	szt.
1	03901	70x70x2200mm	4
1a	06453	70x70x2200mm	2
1b	06467	70x70x2200mm	2

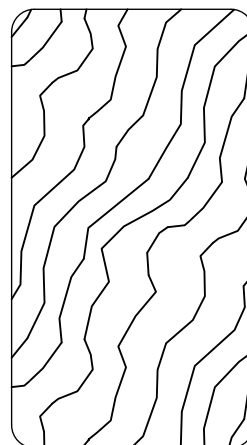

- **3,2 x 5,8 cm**

Lp.	Kod	Wymiary [mm]	szt.
2a	04613	32x58x1300mm	2
3	04457	32x58x800mm	5
4	04615	32x58x690mm	1
5	04459	32x58x628mm	3
6	04617	32x58x610mm	2
7	04619	32x58x550mm	2
8a	04461	32x58x350mm	1
9a	04463	32x58x296mm	1
10	04621	32x58x250mm	1

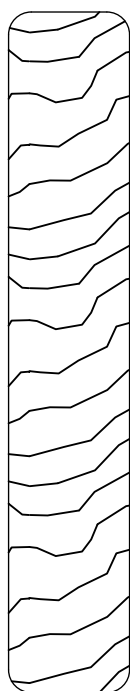

- **1,6 x 9,0 cm**

Lp.	Kod	Wymiary [mm]	szt.
11a	03920	16x90x1200mm	1
12	04465	16x90x800mm	43
13	04096	16x90x660mm	1
14	04625	16x90x600mm	6
15a	04467	16x90x560mm	2
16a	04469	16x90x325mm	1

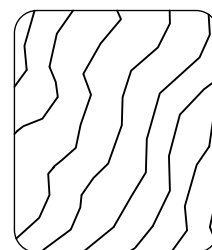

- **2,7 x 3,2 cm**

Lp.	Kod	Wymiary [mm]	szt.
17a	04471	27x32x542mm	2

01

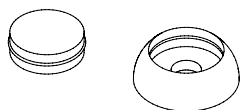
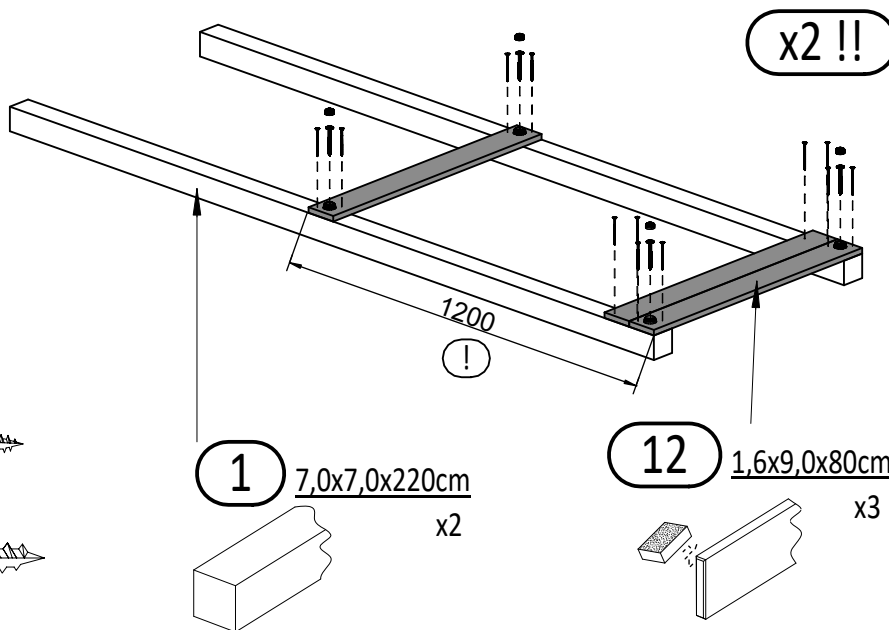
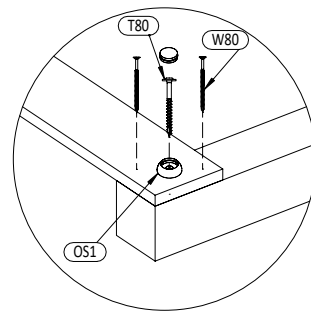
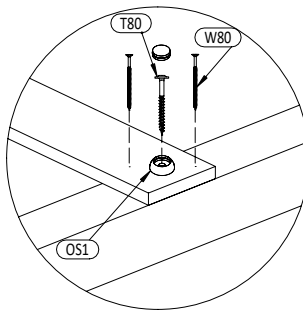
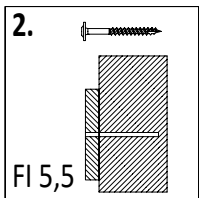
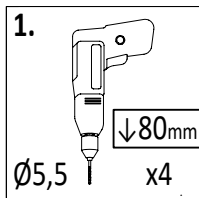

OS1 x4\*2 = 8



W80 x12\*2 = 24

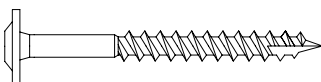

T80 x4\*2 = 8

02

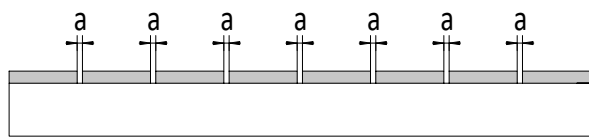
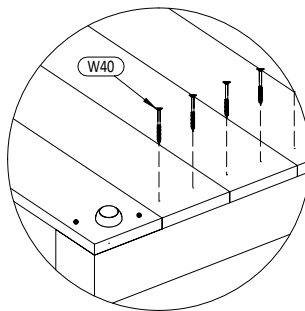
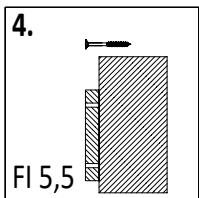
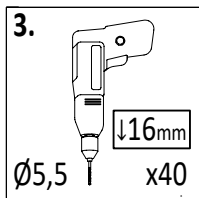

!!!min 2mm < a < !!!max 6mm

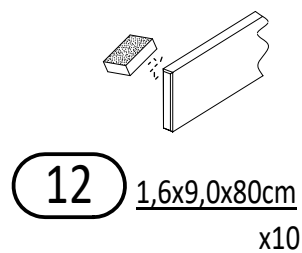

W40 x40

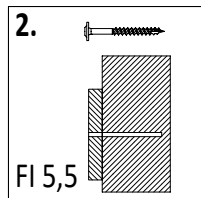
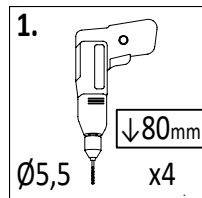
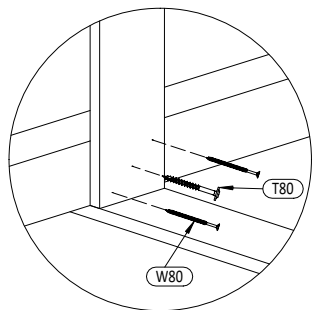

**12** 1,6x9,0x80cm  
x6

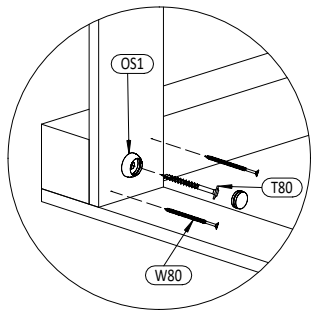
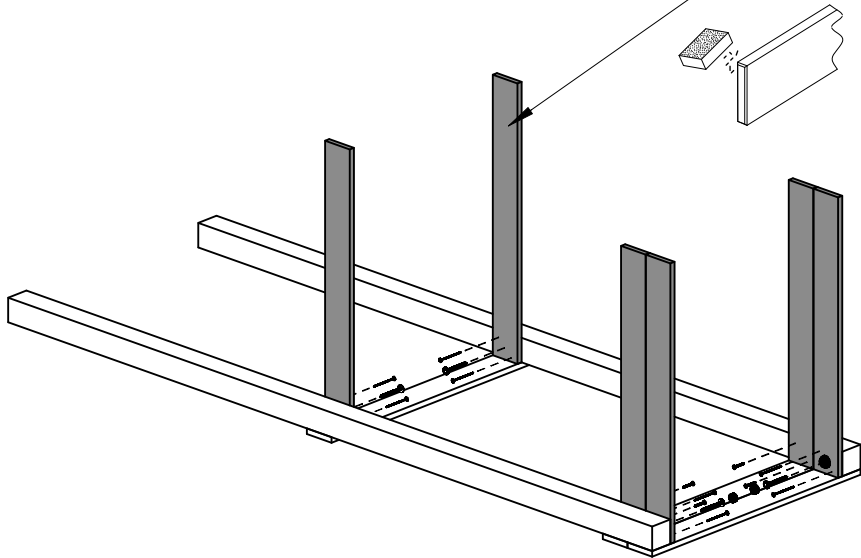

- OS1 x2
- W80 x12
- T80 x4

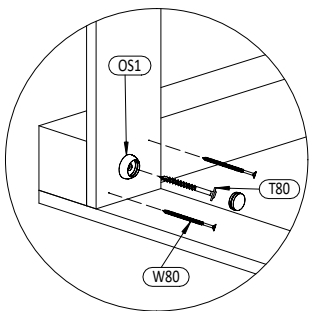
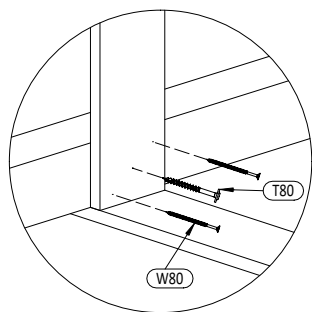
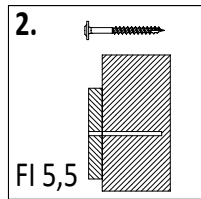
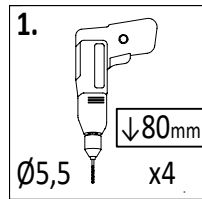
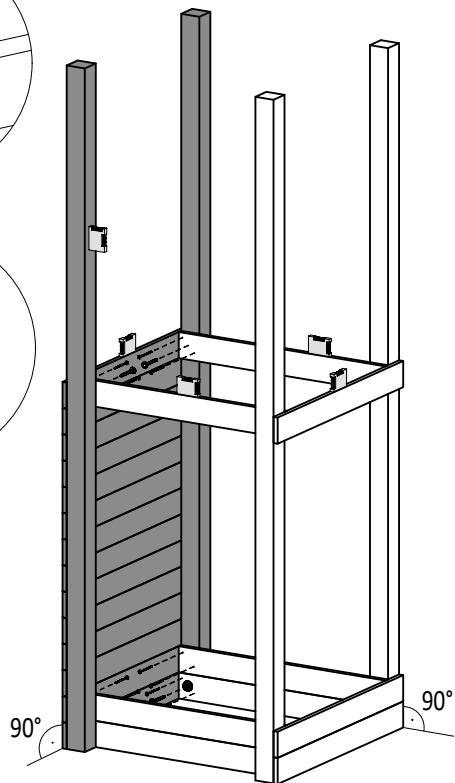
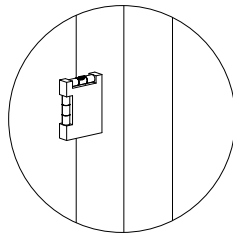
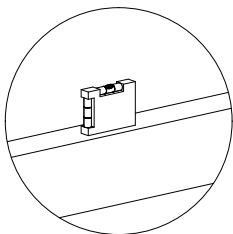

- OS1 x2
- W80 x12
- T80 x4

05

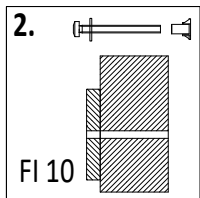
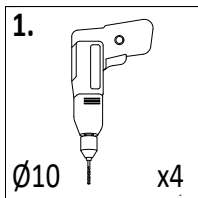

5

3,2x5,8x62,8cm x2

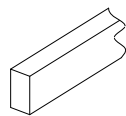

OS1 x4

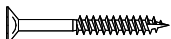

W40 x4

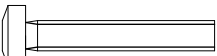

S50 x4



P17 x4



L11 x4

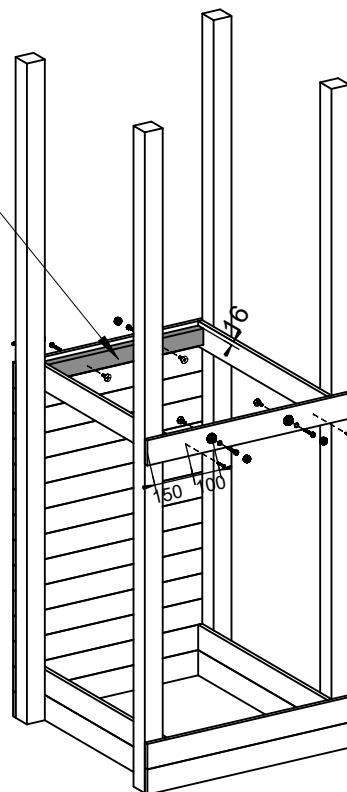
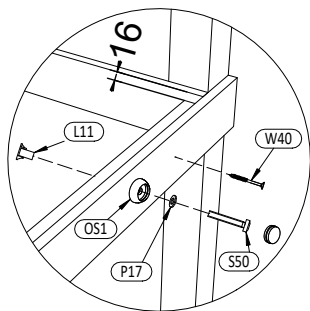

06

5

3,2x5,8x62,8cm x1

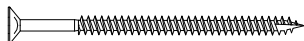
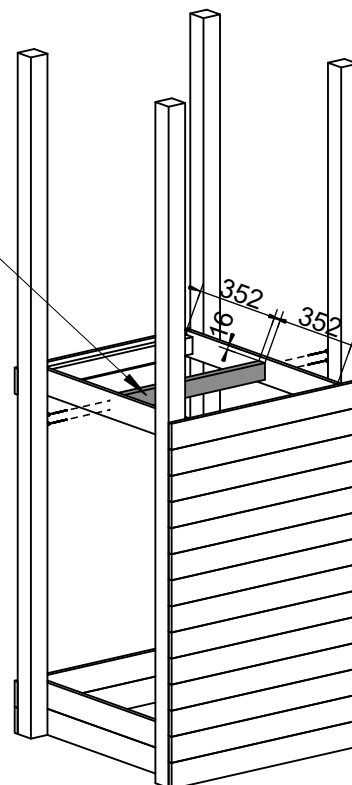
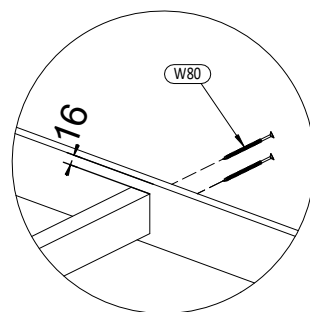
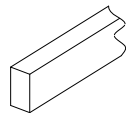

W80 x4



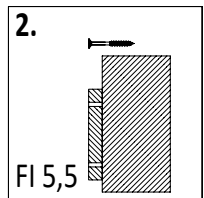
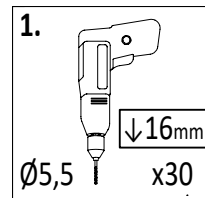
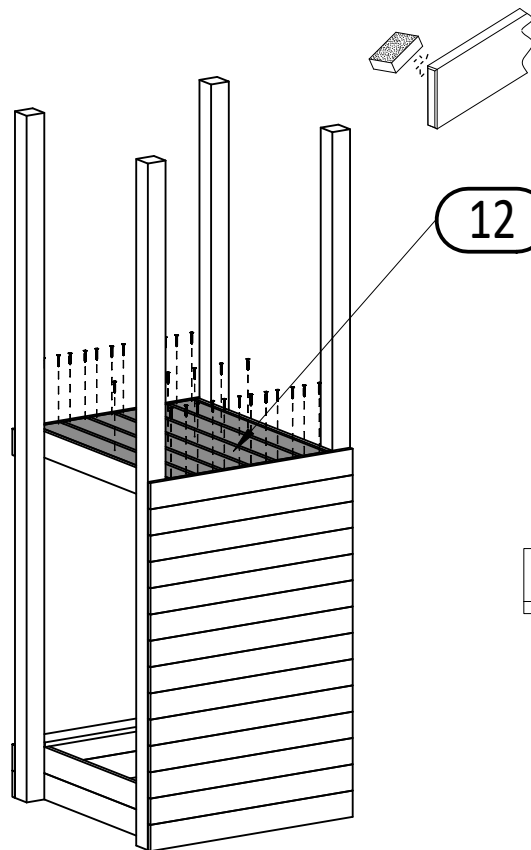

12 1,6x9,0x80cm  
x6

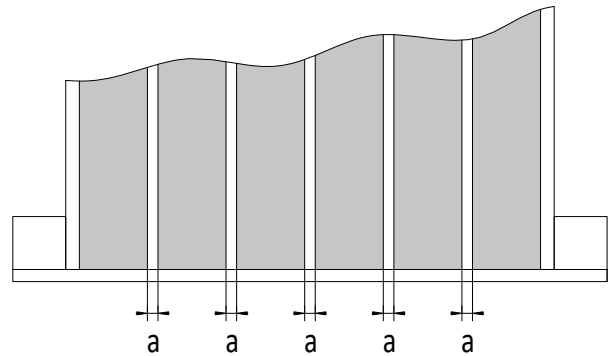

!!!min 13mm < a <!!!max 18mm

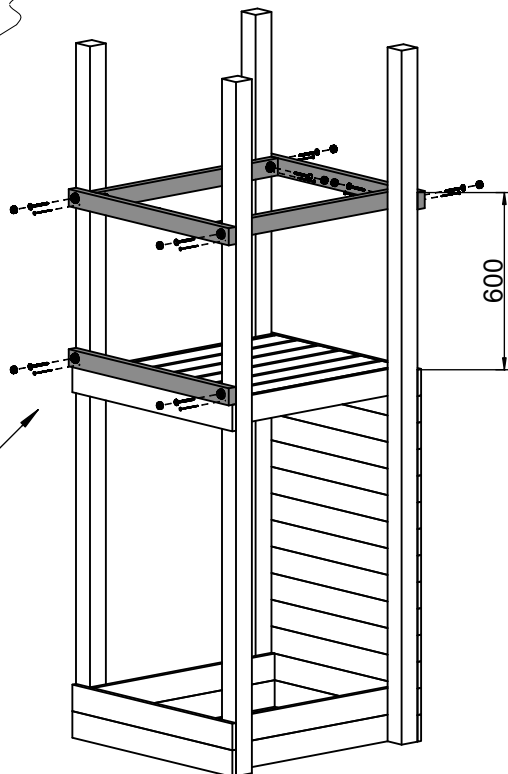
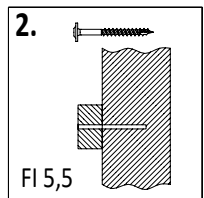
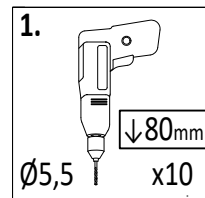
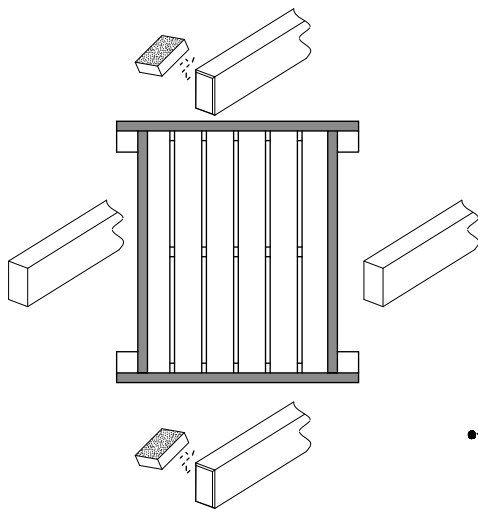
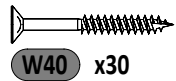

3 3,2x5,8x80cm  
x5

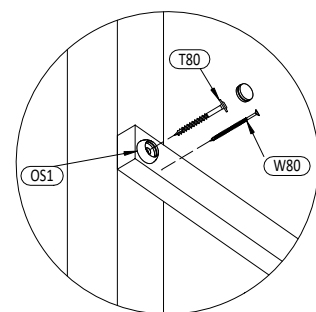

OS1 x10



W80 x10

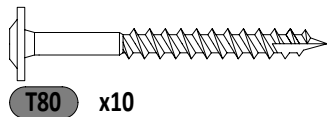

T80 x10

Zgodne z normą PN-EN 71 stosuj zalecenia producenta odnośnie odległości oraz metody mocowania poszczególnych elementów  
 In compliance with the standard PN-EN 71, apply guidelines of the producer in relation to distances and methods of fastening individual elements

09

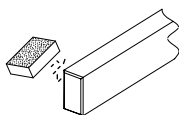
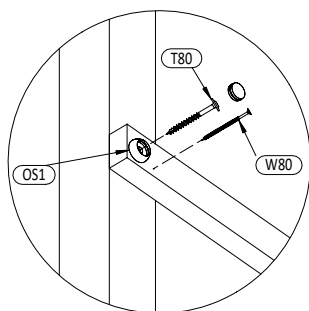
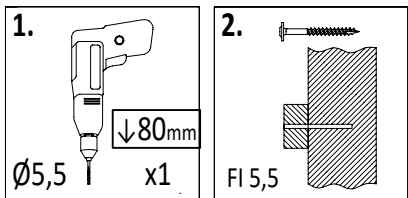

**10** 3,2x5,8x25cm  
x1



OS1 x1



W80 x1

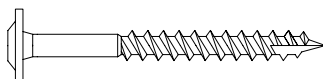

T80 x1

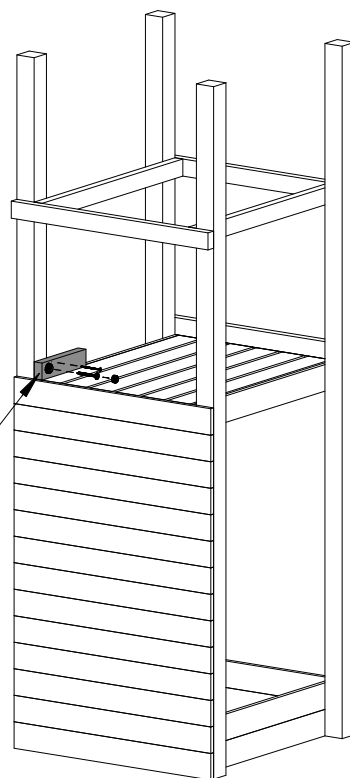

10

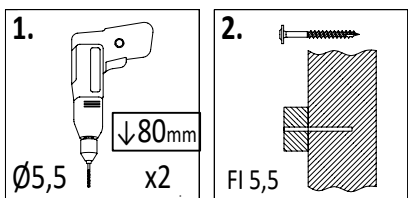

**4** 3,2x5,8x69cm  
x1

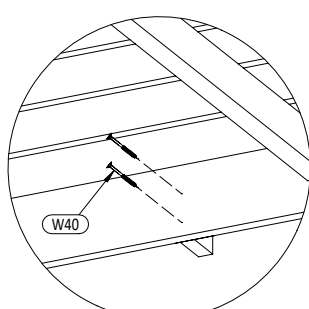
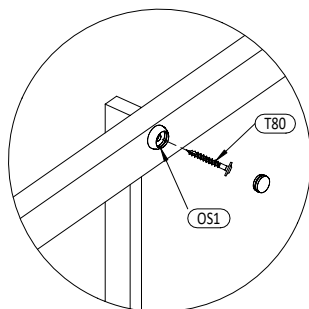

OS1 x2



W40 x2

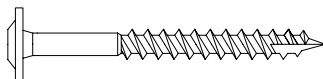

T80 x2

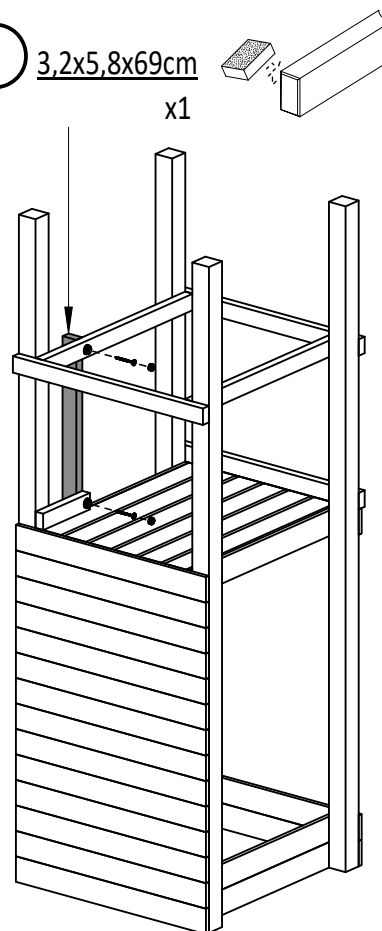

17a 2,7x3,2x54,2cm  
x2

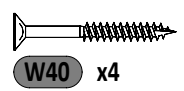
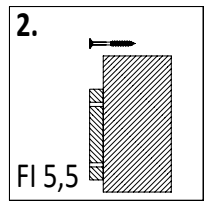
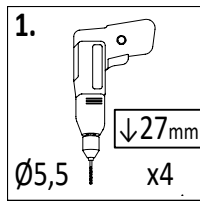
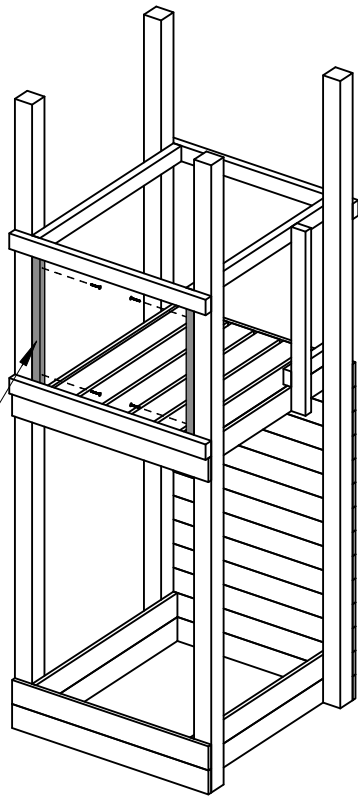

14 1,6x9,0x60cm  
x5

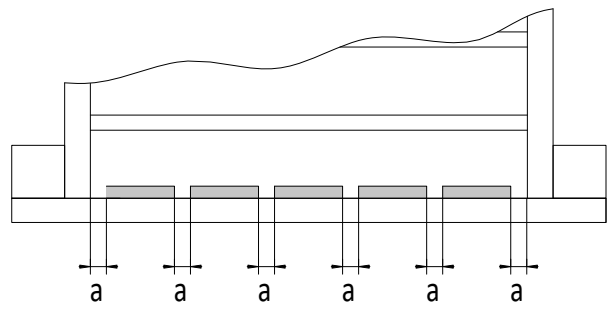
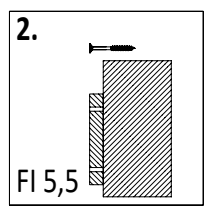
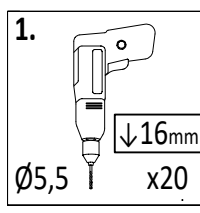
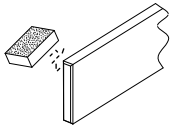
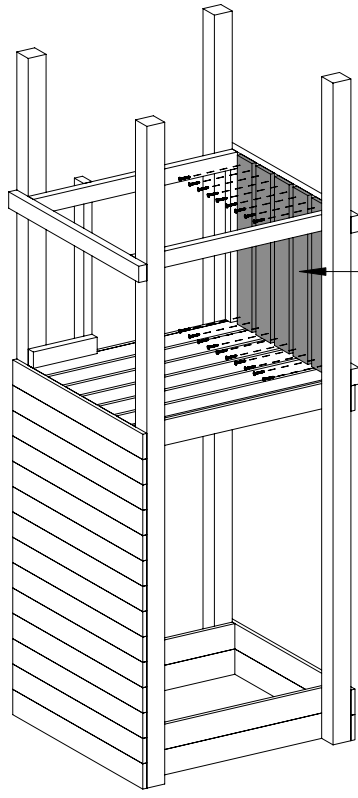

!!!min 13mm < a < !!!max 23mm

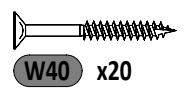

Zgodne z normą PN-EN 71 stosuj zalecenia producenta odnośnie odległości oraz metody mocowania poszczególnych elementów  
In compliance with the standard PN-EN 71, apply guidelines of the producer in relation to distances and methods of fastening individual elements

13

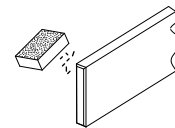
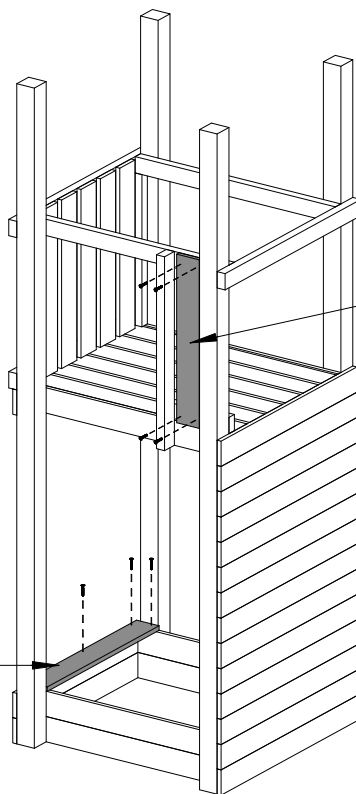
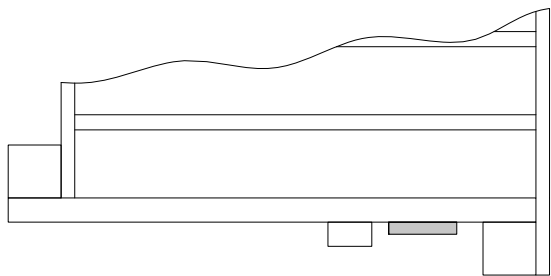
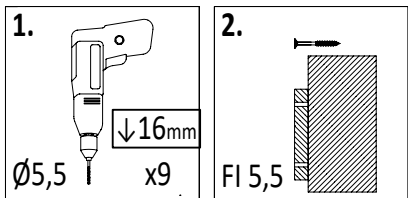

14  $1,6 \times 9,0 \times 60\text{cm}$   
x1

13  $1,6 \times 9,0 \times 66\text{cm}$   
x1

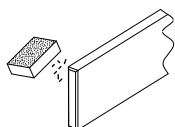
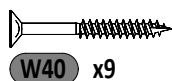

14

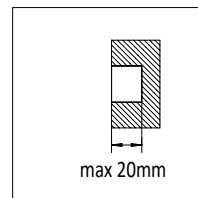
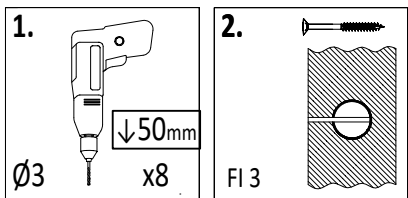

2a  $3,2 \times 5,8 \times 130\text{cm}$   
x2

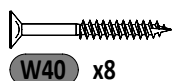
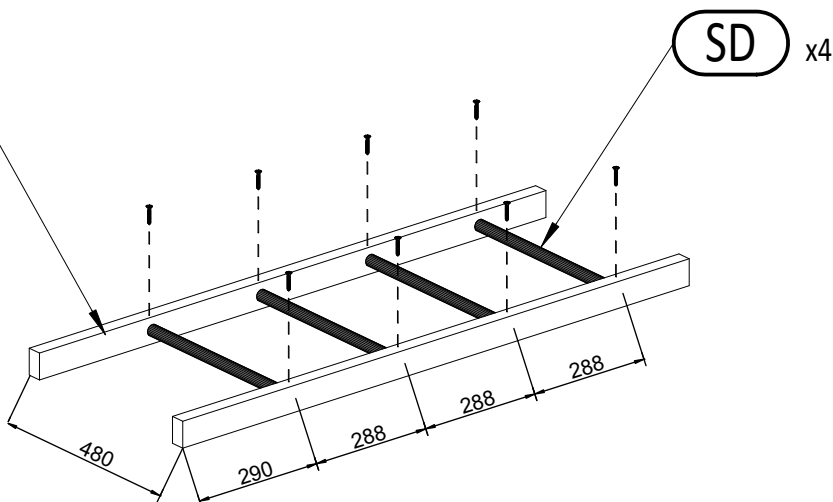
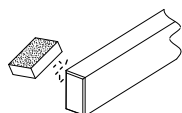

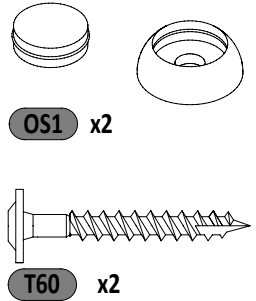
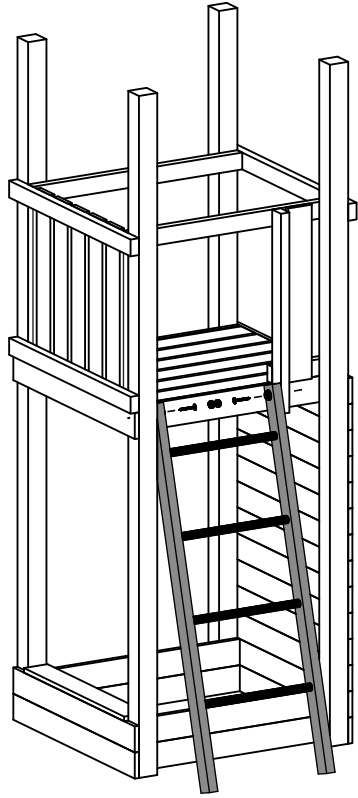
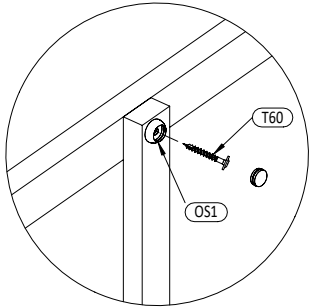
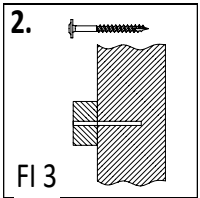
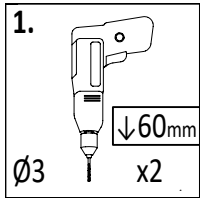

x2

15a 1,6x9,0x56cm  
x1

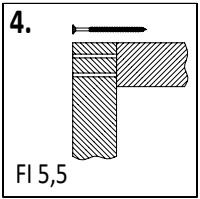
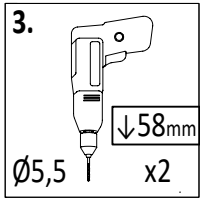
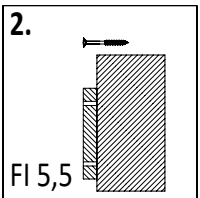
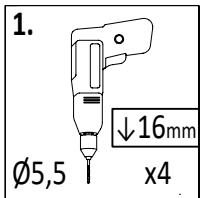
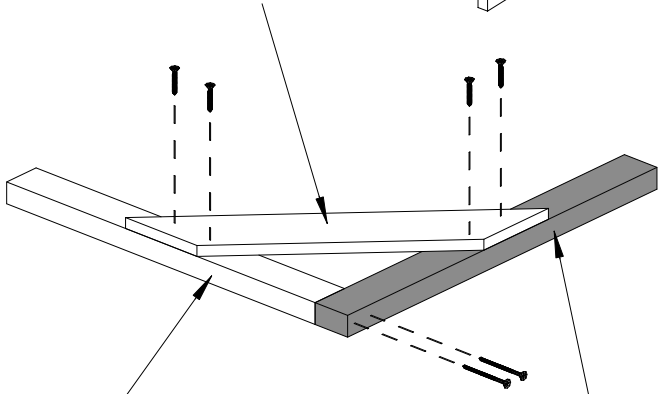
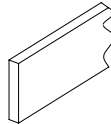

7 3,2x5,8x55cm  
x1

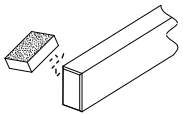

6 3,2x5,8x61cm  
x1

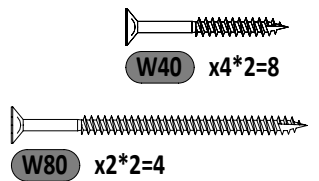
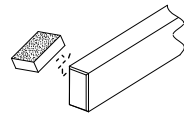

Zgodne z normą PN-EN 71 stosuj zalecenia producenta odnośnie odległości oraz metody mocowania poszczególnych elementów  
 In compliance with the standard PN-EN 71, apply guidelines of the producer in relation to distances and methods of fastening individual elements

17

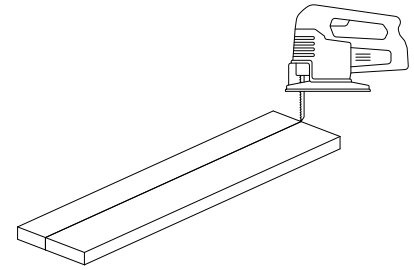
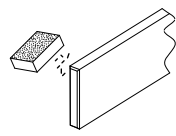
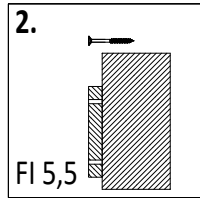
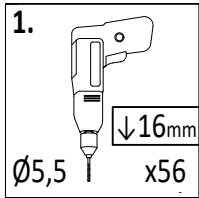

**12**  $1,6 \times 9,0 \times 80\text{cm}$   
x14

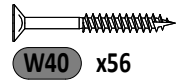
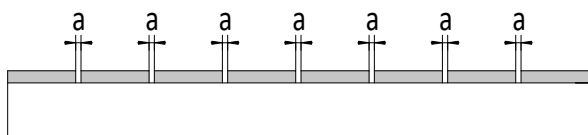
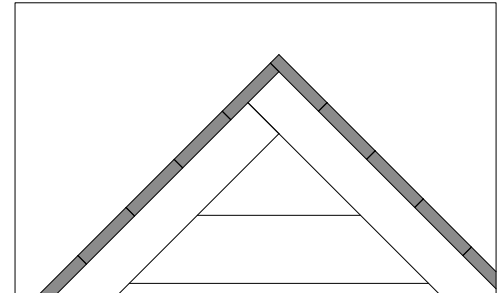
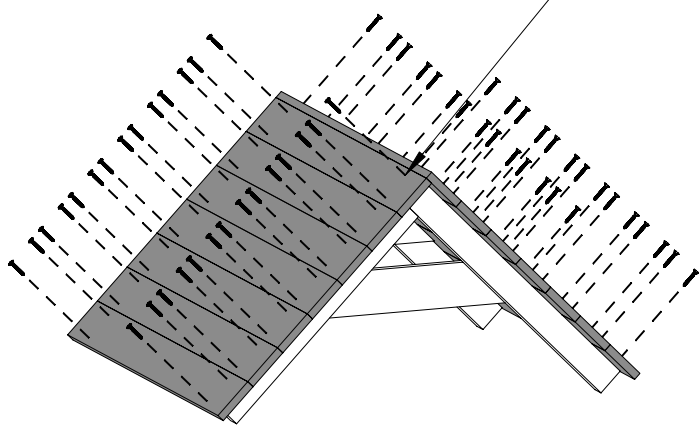

!!!min 2mm < a < !!!max 6mm

18

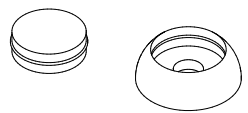
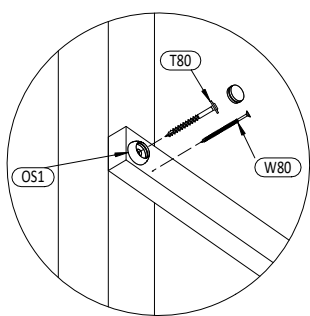
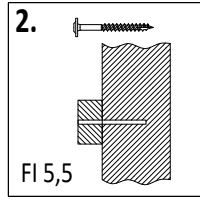
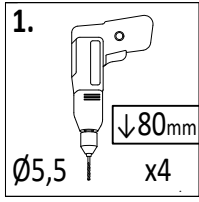

**OS1** x4



**W80** x4

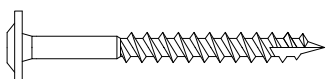

**T80** x4

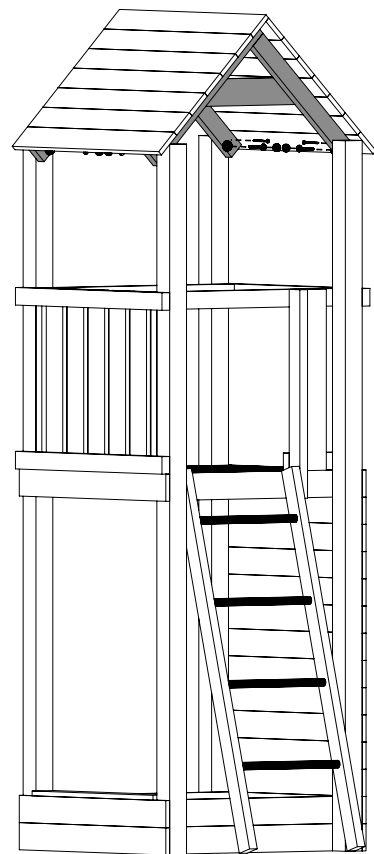

**14** FLAPPI V2

Zgodne z normą PN-EN 71 stosuj zalecenia producenta odnośnie odległości oraz metody mocowania poszczególnych elementów  
 In compliance with the standard PN-EN 71, apply guidelines of the producer in relation to distances and methods of fastening individual elements

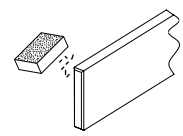

**11a** 1,6x9,0x120cm

x1

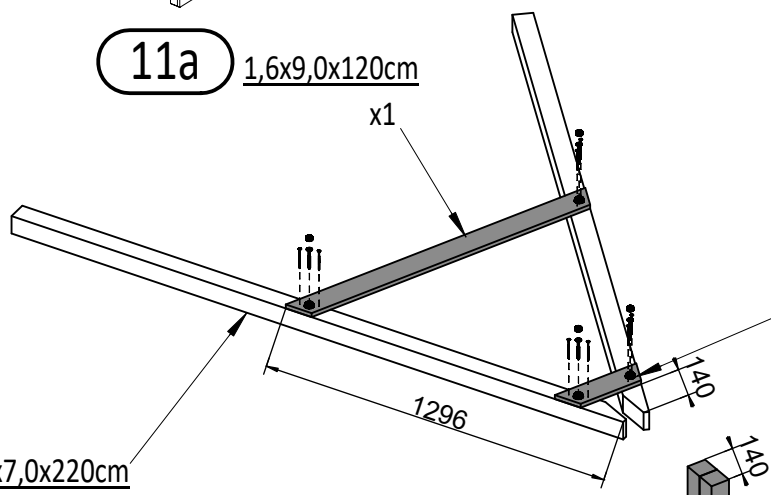
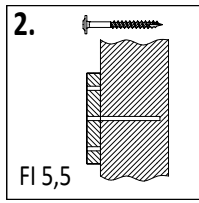
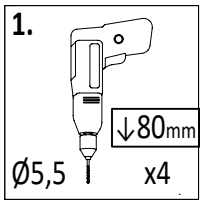

**16a** 1,6x9,0x32,6cm

x1

**1a** 7,0x7,0x220cm

x2

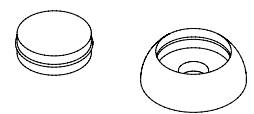
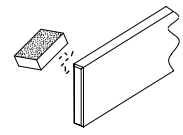
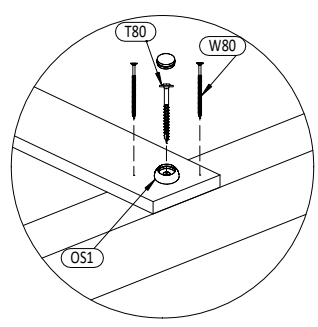
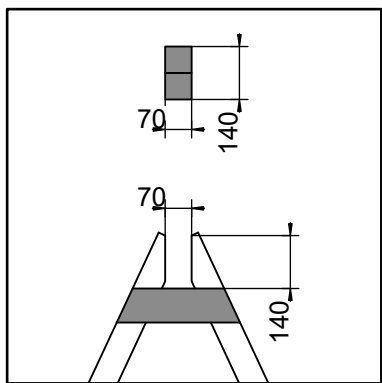

**OS1** x4

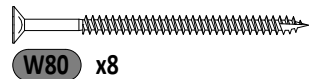

**W80** x8



**T80** x4

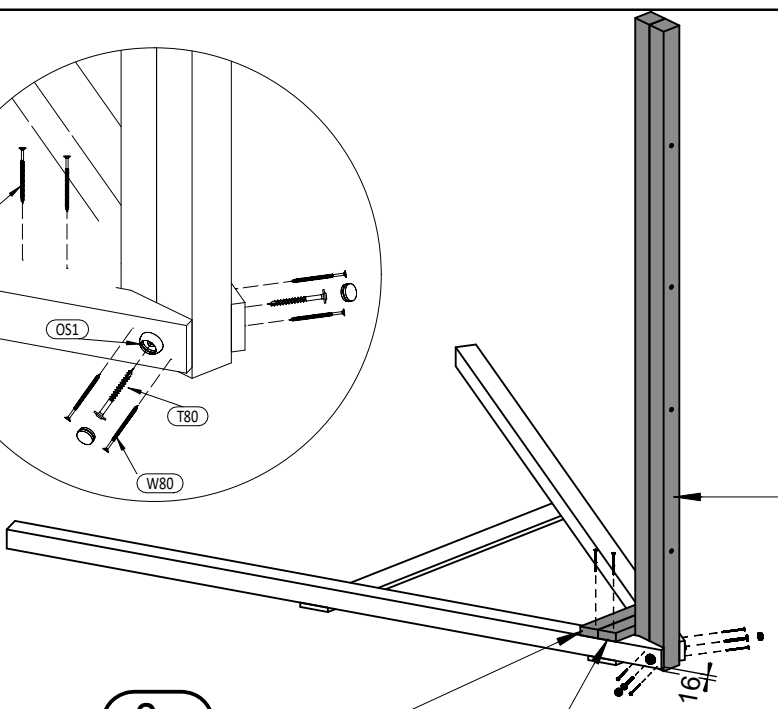
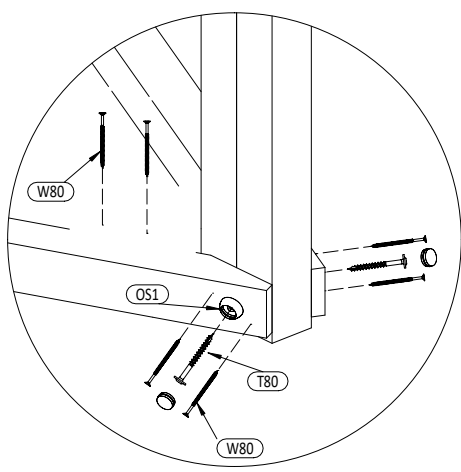
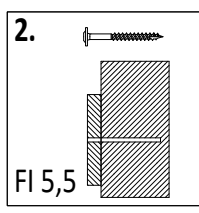
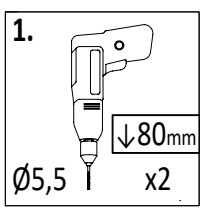

**1b** 7,0x7,0x220cm

x2

**8a** 3,2x5,8x35cm

x1

**9a** 3,2x5,8x29,6cm

x1

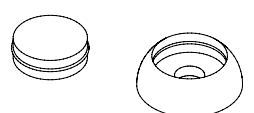
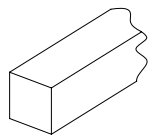

**OS1** x2

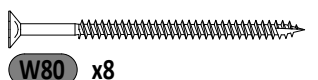

**W80** x8

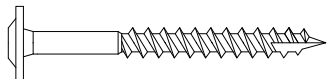

**T80** x2

Zgodnie z normą PN-EN 71 stosuj zalecenia producenta odnośnie odległości oraz metody mocowania poszczególnych elementów  
In compliance with the standard PN-EN 71, apply guidelines of the producer in relation to distances and methods of fastening individual elements

21

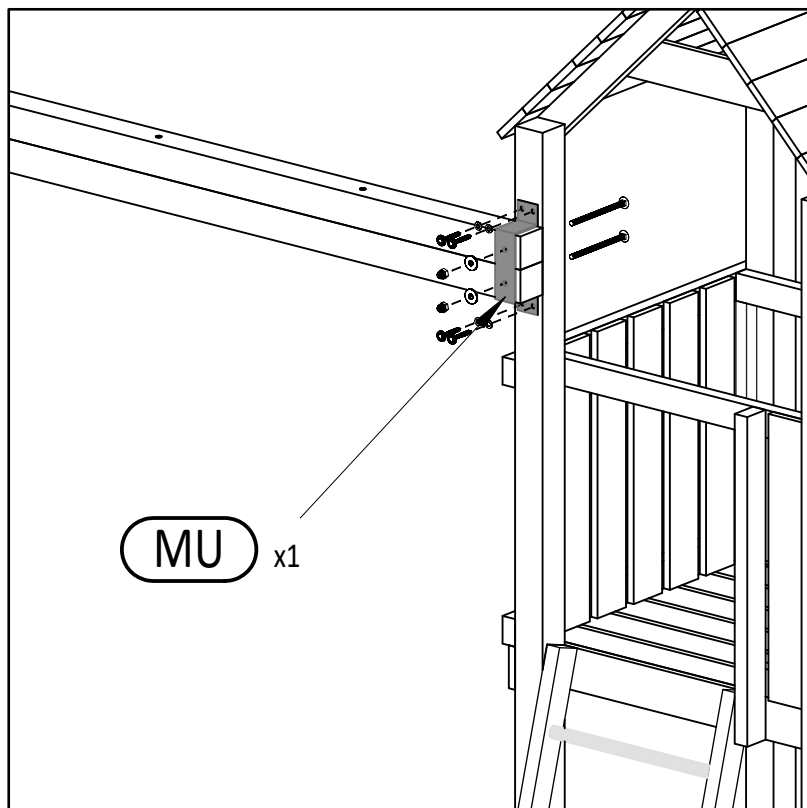
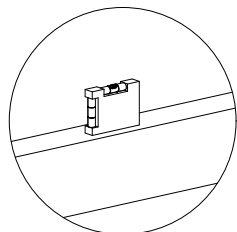
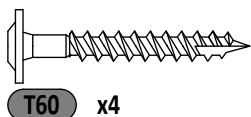
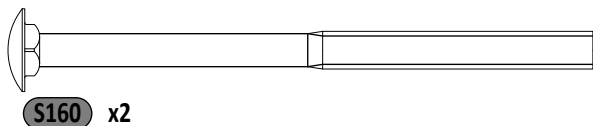
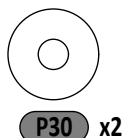
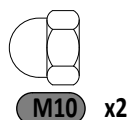
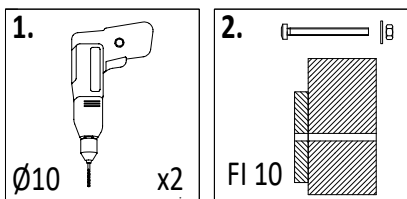
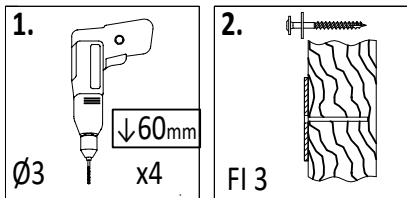

22

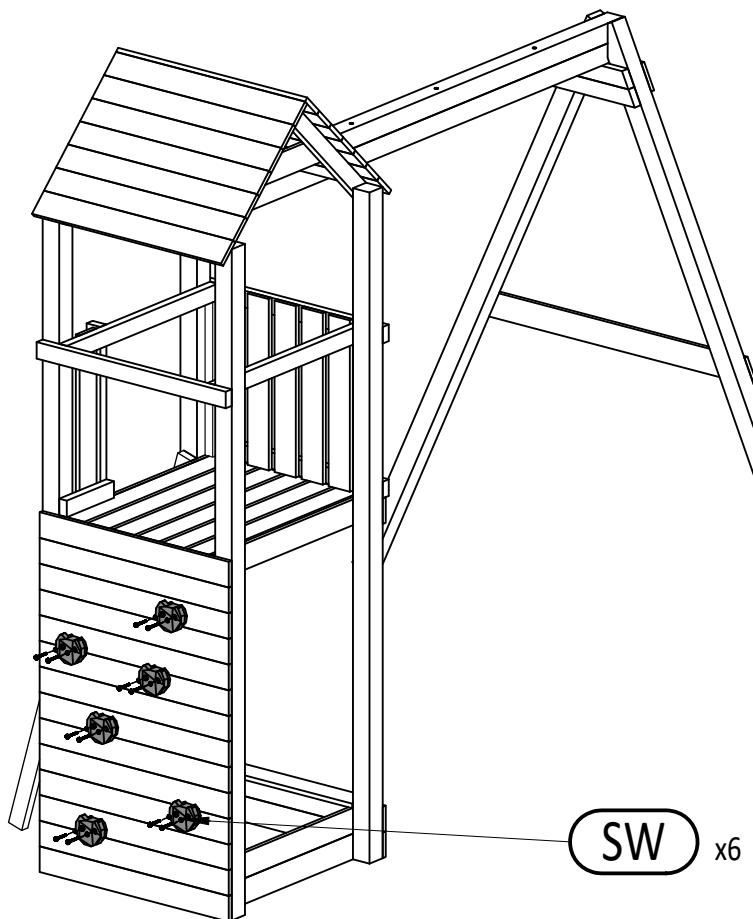
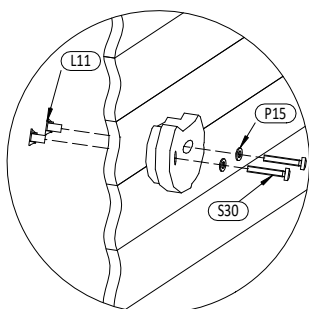
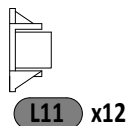
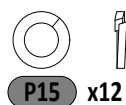
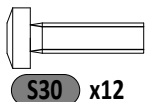
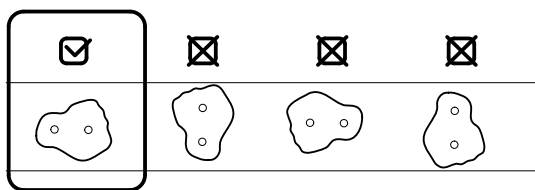
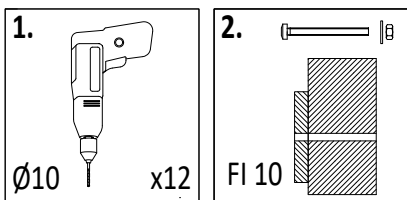



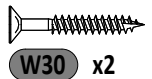
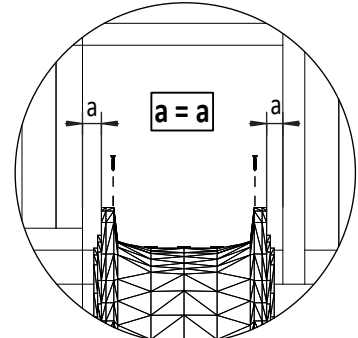
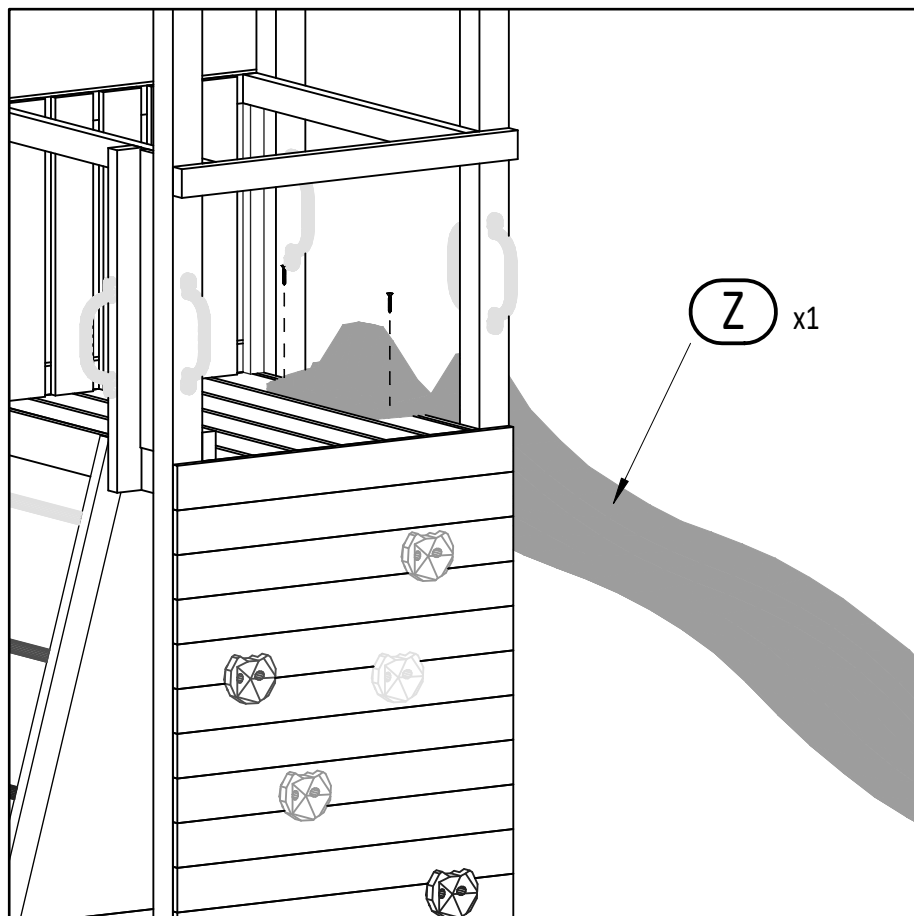
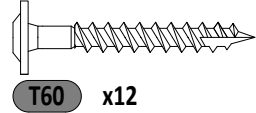
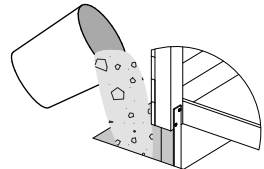
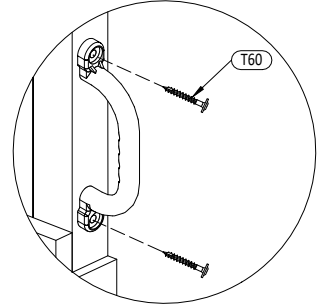
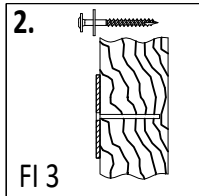
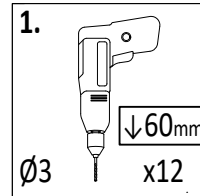
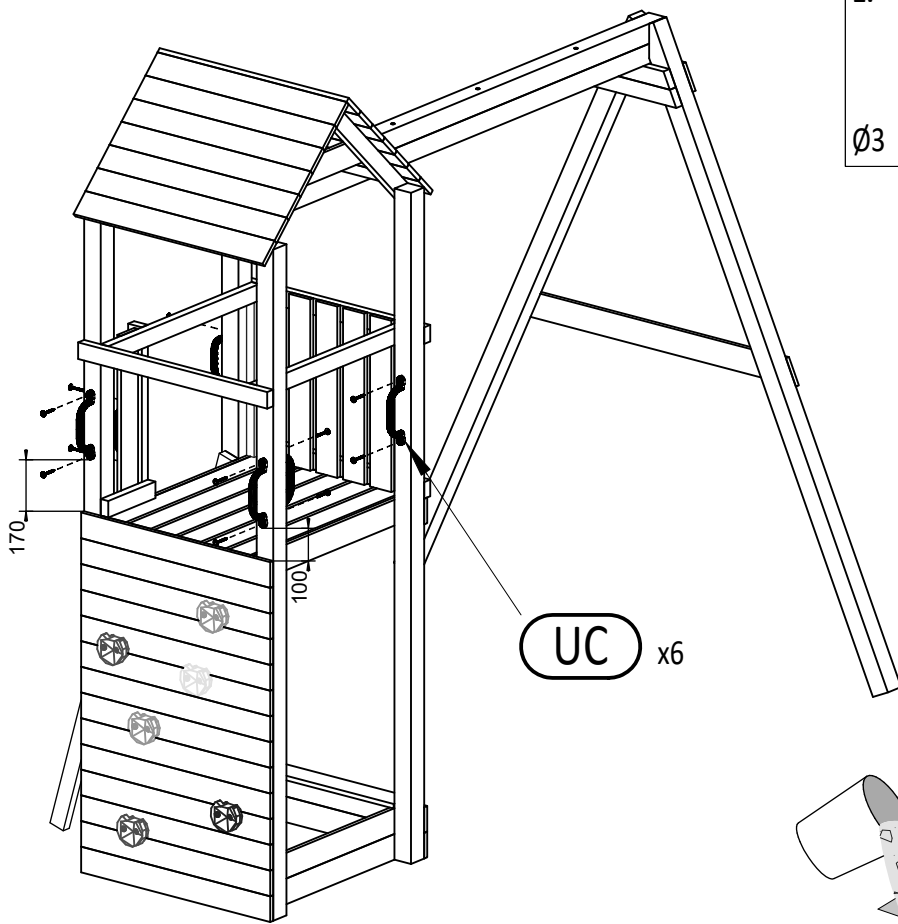

Zgodnie z normą PN-EN 71 stosuj zalecenia producenta odnośnie odległości oraz metody mocowania poszczególnych elementów  
 In compliance with the standard PN-EN 71, apply guidelines of the producer in relation to distances and methods of fastening individual elements

25

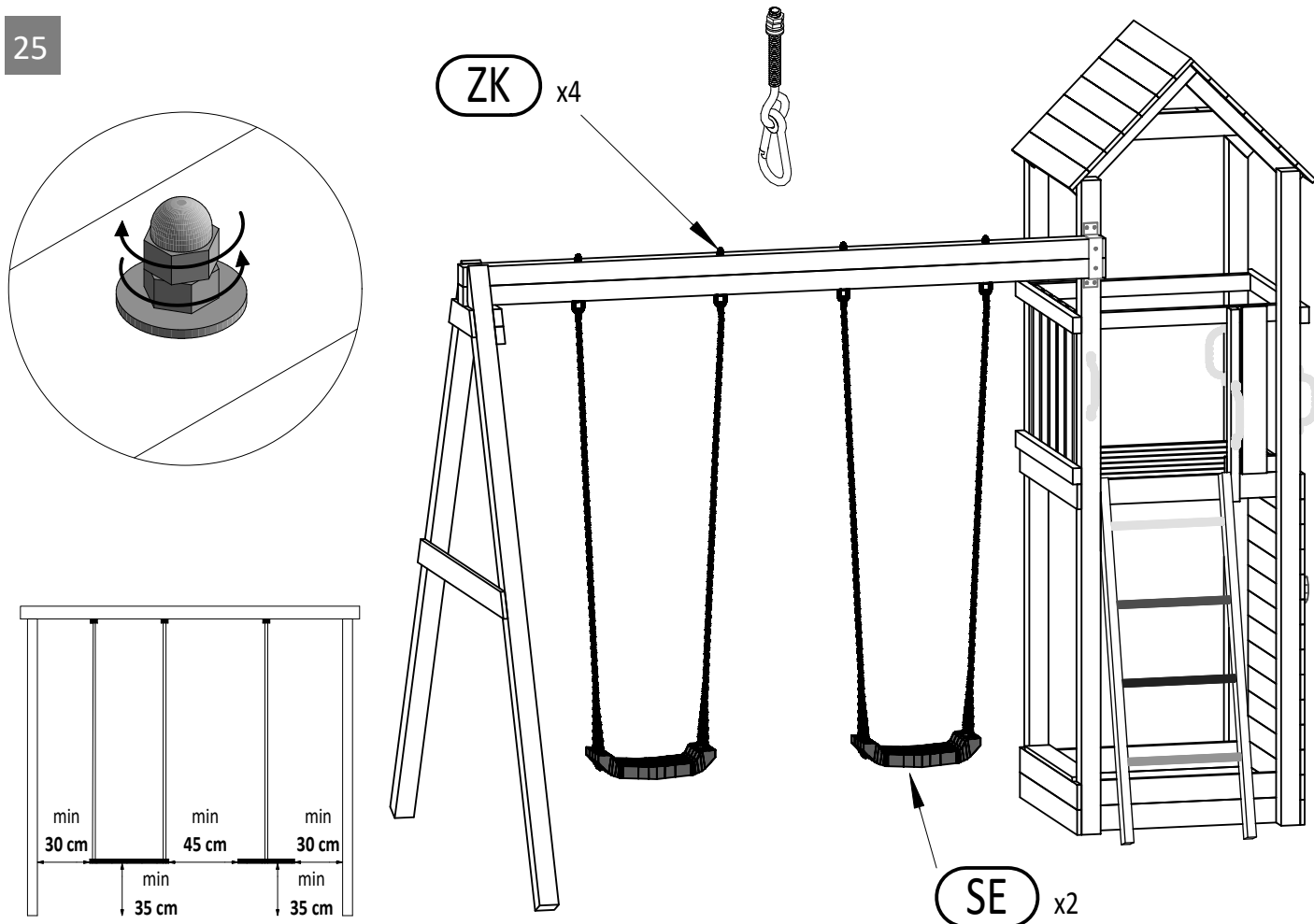

26

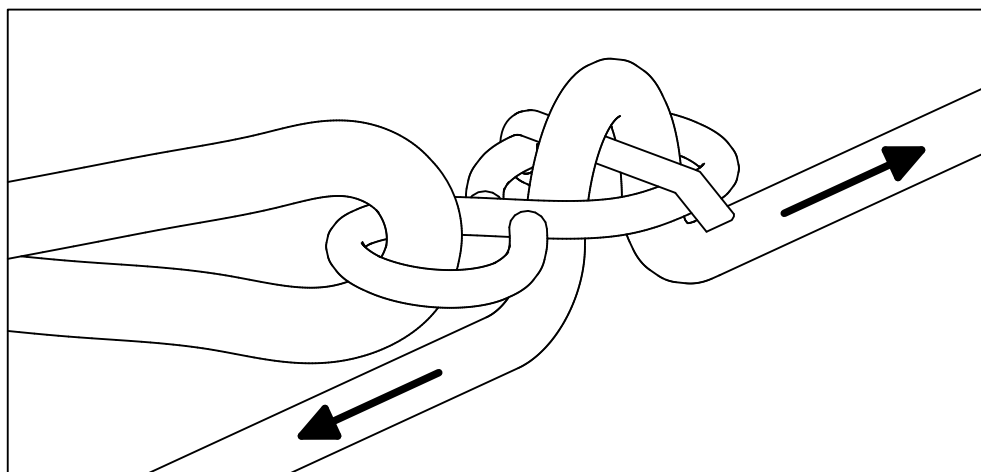

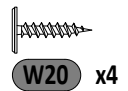
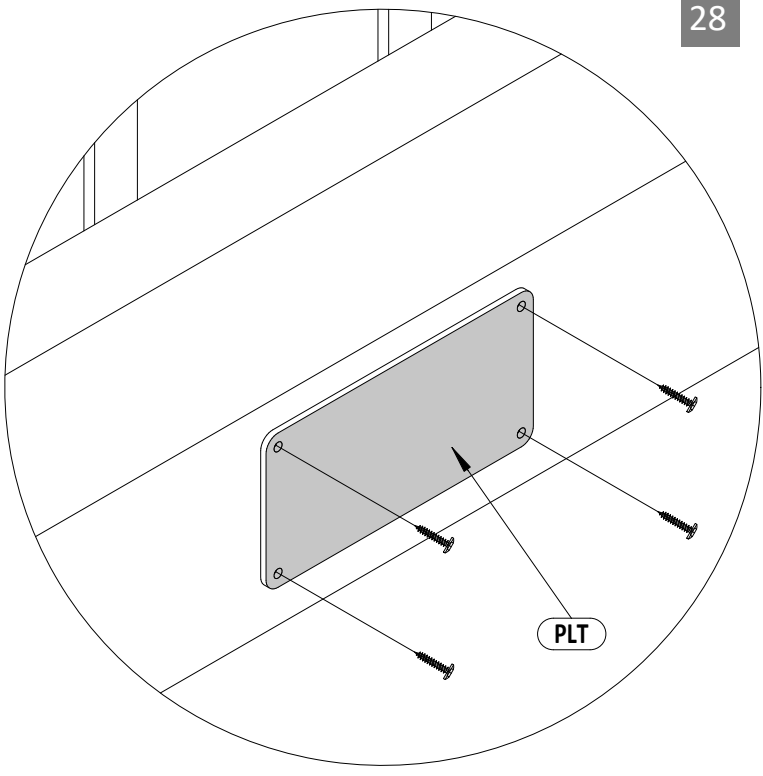
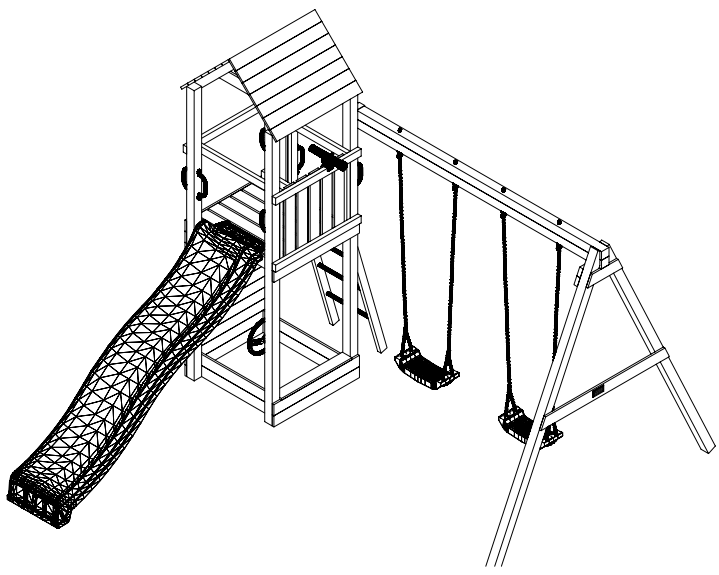
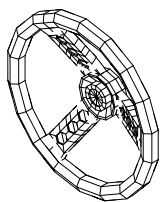
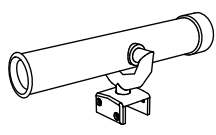
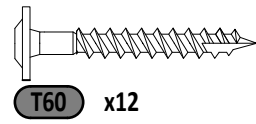
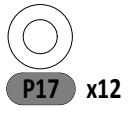
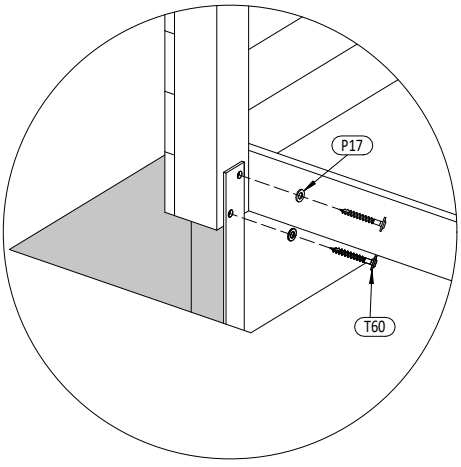
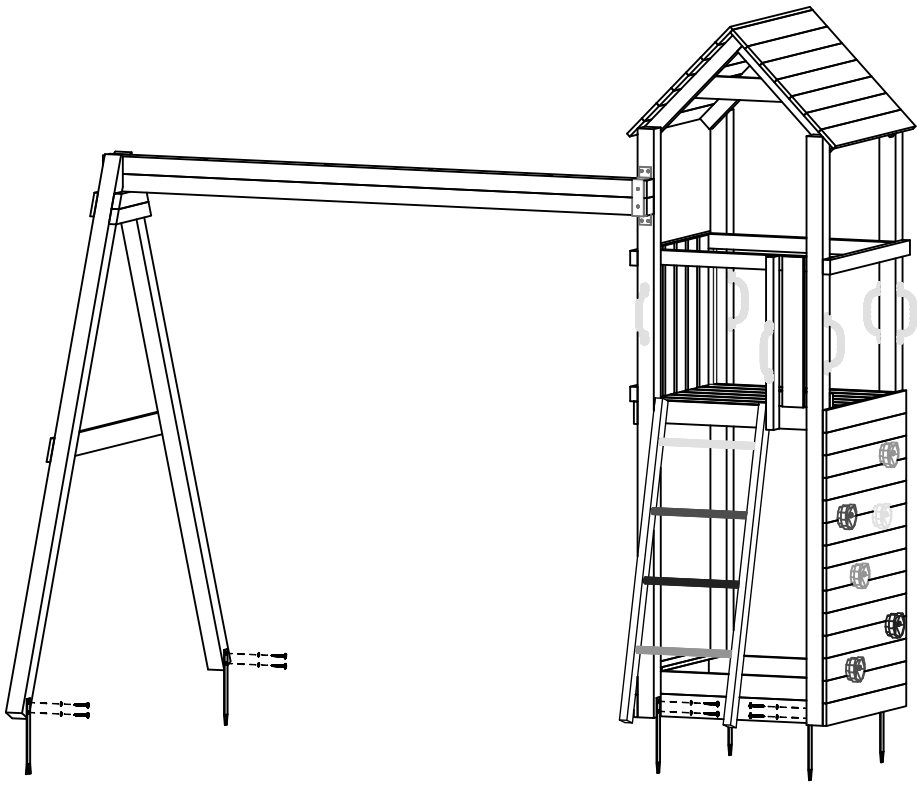
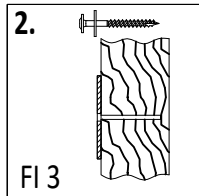
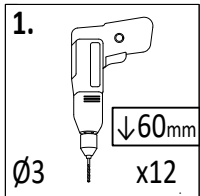

Zgodnie z normą PN-EN 71 stosuj zalecenia producenta odnośnie odległości oraz metody mocowania poszczególnych elementów  
 In compliance with the standard PN-EN 71, apply guidelines of the producer in relation to distances and methods of fastening individual elements